



PORTUGAL

SLIDER 800

sliding gate operator
moteurs pour portes coulissantes



move[®]
automation 



SLIDER 800

sliding gate operator
moteurs pour portes coulissantes

Choice sélection

A unique technology, offers a range of solutions and complete applications.
D'une technologie unique, une gamme de solutions et d'applications complètes.

Duration durée

A long-term use technology.
Une technologie et une utilisation à long terme.

Quality qualité

Automating sliding gates in line, up to a maximum weight of 800KG
Automatisation des portes coulissantes, jusqu'à un poids maximal de 800 kg

Safety sécurité

State-of-the-art electronics for perfect security.
Électronique développée pour une sécurité parfaite.

Customization personnalisation

Easy installation thanks to clear, simple and intuitive instructions.
Installation facile grâce aux instructions claires, simples et intuitives.

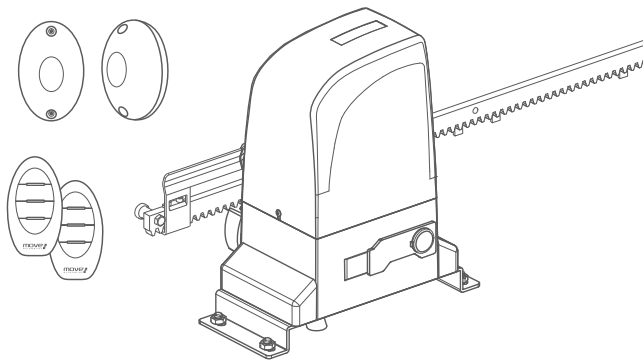

ECO KIT COMPOSITION:

- 1 Motor
- 1 Electronic Central
- 2 Remote Controls
- 1 Set of Photocells
- Mounting Accessories
- 4 meters of nylon rack

COMPOSANTS DE L'ECO KIT:

- 1 Moteur
- 1 Centrale électronique
- 2 Commandes
- 1 Jeu de Photocellules
- Accessoires de montage
- 4 mètres de crémaillère nylon

TECHNICAL DATA DONNÉES TECHNIQUES	SLIDER 800
POWER SUPPLY Alimentation	230Vac 50Hz
POWER Puissance	370W
RPM	1200
WORKING TEMPERATURE Temperature	-25°C a 55°C
IP PROTECTION niveau de protection	IP44
MAXIMUM WEIGHT OF LEAF Poids maximum par vantail	800Kg
WORKING TIME Temps de fonctionnement	15min
THERMAL PROTECTION Protection thermique	120°
CAPACITOR Condensateur	12µF
WORKING FREQUENCY Frequence de travail	40%

