

# base

motores ao eixo para portas de garagem industriais

ES. motores al eje para puertas de garaje industriales

FR. moteurs à arbre pour portes de garage industrielles

EN. shaft motors for industrial garage doors



DADOS TÉCNICOS		35	50	70	120
FR. Informations Techniques EN. Technical Data					
STANDARD LIFT	ÁREA MÁX. DA PORTA ES. Área máxima de la puerta FR. Surface max. de la porte EN. Max. door area	18.0 m <sup>2</sup>	24.0 m <sup>2</sup>	30.0 m <sup>2</sup>	40.0 m <sup>2</sup>
	PESO MÁX. DA PORTA ES. Peso máximo de la puerta FR. Poids max. de la porte EN. Max. door Weight	234 kg	312 kg	390 kg	540 kg
HIGH LIFT	ÁREA MÁX. DA PORTA ES. Área máxima de la puerta FR. Surface max. de la porte EN. Max. door area	18.0 m <sup>2</sup>	24.0 m <sup>2</sup>	30.0 m <sup>2</sup>	40.0 m <sup>2</sup>
	PESO MÁX. DA PORTA ES. Peso máximo de la puerta FR. Poids max. de la porte EN. Max. door Weight	234 kg	312 kg	390 kg	520 kg
VERTICAL LIFT	ÁREA MÁX. DA PORTA ES. Área máxima de la puerta FR. Surface max. de la porte EN. Max. door area	14.0 m <sup>2</sup>	20.0 m <sup>2</sup>	26.0 m <sup>2</sup>	36.0 m <sup>2</sup>
	PESO MÁX. DA PORTA ES. Peso máximo de la puerta FR. Poids max. de la porte EN. Max. door Weight	182 kg	260 kg	338 kg	468 kg
FORÇA MÁXIMA	ES. Fuerza Maxima FR. Force Maximale EN. Max. Output Torque	35 Nm	50 Nm	70 Nm	140 Nm
FORÇA NOMINAL	ES. Fuerza Nominal FR. Force Nominale EN. Rated Output Torque	25 Nm	35 Nm	50 Nm	120 Nm
RPM	ES. Max. Velocidad de salida FR. Max. Vitesse de Sortie EN. Max. Output Speed	24 - 32 RPM			12 - 32 RPM
TENSÃO DE ENTRADA	ES. Voltaje de entrada FR. Tension d'entrée EN. Input voltage	110/220(1+10%)V 60Hz/50Hz 380v-420V			
POTÊNCIA DO MOTOR	ES. Potencia del motor FR. Puissance du moteur EN. Motor Power	350 W	450 W	550 W	850 W
EIXO Ø	ES. Ø Eje FR. Ø Arbre EN. Ø Shaft	Ø 25.4 mm			Ø 25.4 / 31.75mm
SISTEMA DE CONTROLE	ES. Sistema de Control FR. Système de Contrôle EN. Control System	24V DC			
MOMENTO ESTÁTICO DE RETENÇÃO	ES. Momento Estática de Retención FR. Moment Statique de Rétention EN. Static Holding Torque	400 Nm			
LIMITE MÁX. DO FIM-DE-CURSO	ES. Limite max. de final de carrera FR. Limite max. du fin-de-cours EN. Operation Limit Turns (limit travel)	≤5 m Altura FR. Hauteur EN. Height	≤8 m Altura FR. Hauteur EN. Height	15 Voltas do Eixo ES. 15 Vueltas del Eje FR. 15 Axe tourne EN. 15 Shaft Turns	
CICLOS MÁX. / HORA	ES. Ciclos máx./hora FR. Cycles max/ heure EN. Max. cycles/ hour	20			
NÍVEL DE PROTEÇÃO	ES. Nivel de protección FR. Niveau de protection EN. Protection grade	IP 54			
TEMPERATURA DE FUNCIONAMENTO	ES. Temperatura de funcionamiento FR. Température de fonctionnement EN. Thermal protection temperature	-20°C ~ +40°C (+60°C)			
CAIXA DE CONTROLE	ES. Caja de Control FR. Boîtier de Commande EN. Control Box	—		INCLUÍDO ES. Incluído FR. Inclus EN. Included	
BOTONEIRA 3 botões	ES. Botonera 3 Botones FR. Boîte de Commande à 3 Boutons EN. Wall Push Button with 3 Buttons	INCLUÍDO ES. Incluído FR. Inclus EN. Included		—	
COMANDOS	ES. Mandos FR. Télécommande EN. Remote Control	OPCIONAL FR. Optionnel EN. Optional			
RECEPTOR	ES. Receptor FR. Récepteur EN. Receiver	OPCIONAL FR. Optionnel EN. Optional			
SUORTE DE FIXAÇÃO	ES. Soporte de Montaje FR. Support de Montage EN. Mounting Bracket	INCLUÍDO ES. Incluído FR. Inclus EN. Included			
EXTENSÃO DE CABO DE ALIMENTAÇÃO 4,5m	ES. Extensión Cable de Alimentación FR. Rallonge Câble d'alimentation EN. Power Cable/Extension	—		INCLUÍDO ES. Incluído FR. Inclus EN. Included	
CORDÃO DE DESEMBRAIMENTO	ES. Cordón de Desbloqueo FR. Cordon de Déverrouillage EN. Quick Release Rope	INCLUÍDO ES. Incluído FR. Inclus EN. Included		—	
MÓDULO CADERNAL	ES. Modulo Cadena FR. Treuil Incorporé EN. Chain Hoist Module	—		INCLUÍDO ES. Incluído FR. Inclus EN. Included	

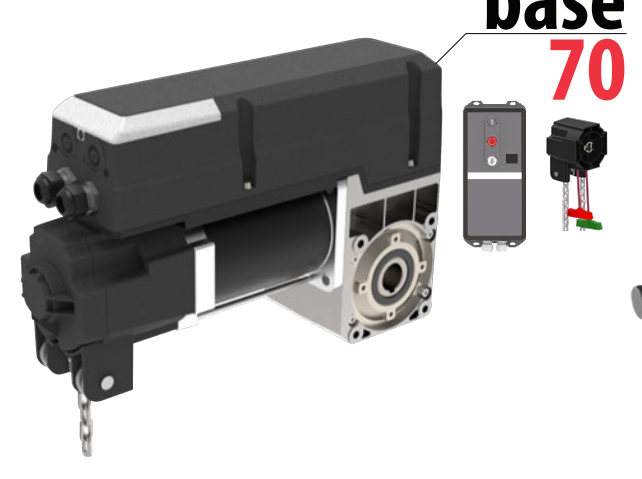
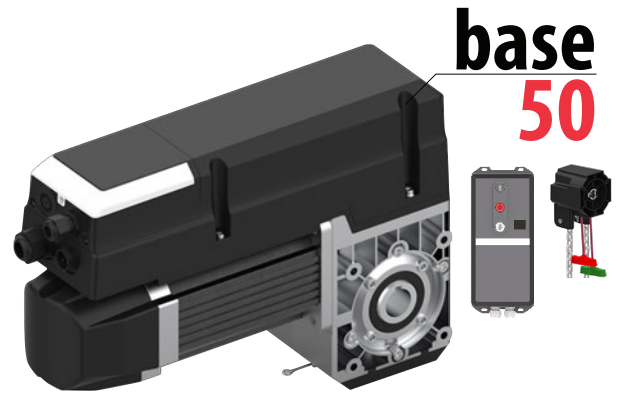
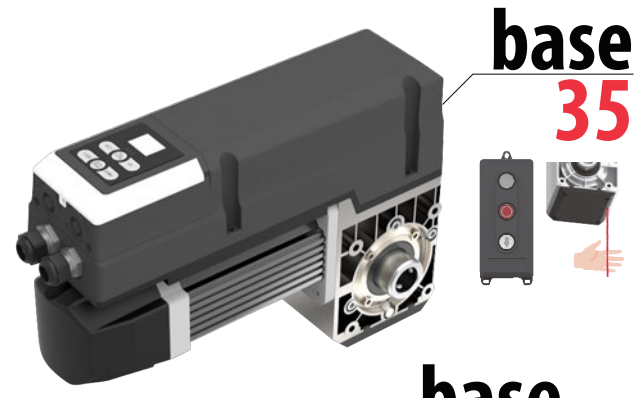
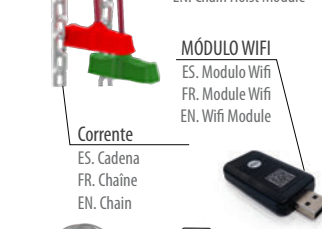
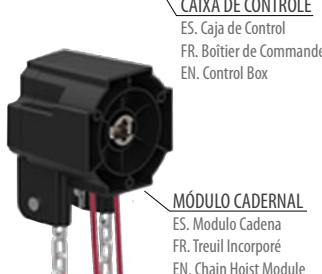
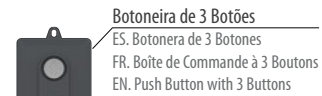

## Motor DC. Rápido, Seguro, Forte e Inteligente.

ES. Motor de corriente continua. Rápido, Seguro, Fuerte e Inteligente.

FR. Moteur DC. Rapide, Sûr, Solide et Intelligent.

EN. DC motor. Fast, Safe, Strong and Smart.

base35 | base50 | base75 | base120

Fast Safe Silent Smart Easy Strong Energy Conservation

CHAPA DE SUPORTE DE MOTOR AJUSTÁVEL (0-130mm)  
ES. Soporte de Pared Ajustable (0-130mm)  
FR. Support Mural Réglable (0-130mm)  
EN. Adjustable Wall Bracket (0-130mm)

